

# EIV

## Applications

Hydro-cyclone filters are used for irrigation water from wells, rivers and lakes, with a considerable amount of suspended sand. The tangential entry of water generates a whirling motion with a centrifugal movement which enables the separation of water and heavy particles. Due to the difference in density, in fact, the water will come out from the top while the heavier sand will precipitate to the centre of the whirlpool accumulating in the specific container beneath. On the bottom of the cone there is a reduction that protects the filters from wear caused by the abrasive action of the sand. The reduction is easily replaceable during routine maintenance operations. Such filters can be equipped with a storage container which allows storage of the separated sand, and discharge it thanks to the the opening of a valve (manual/electric) at constant intervals.

## Materials

- Body: in sanded metal treated with phosphate zinc and followed by an electrostatic application of a layer of polyester paint, minimum thickness 160 micron, with a protective and anti-corrosion function.
- Gaskets: EPDM

## Characteristics

- Maximum working pressure: 8 bar
- Types of connection: threaded, flanged, victaulic
- The filter is supplied with a discharge valve



## Load loss\*

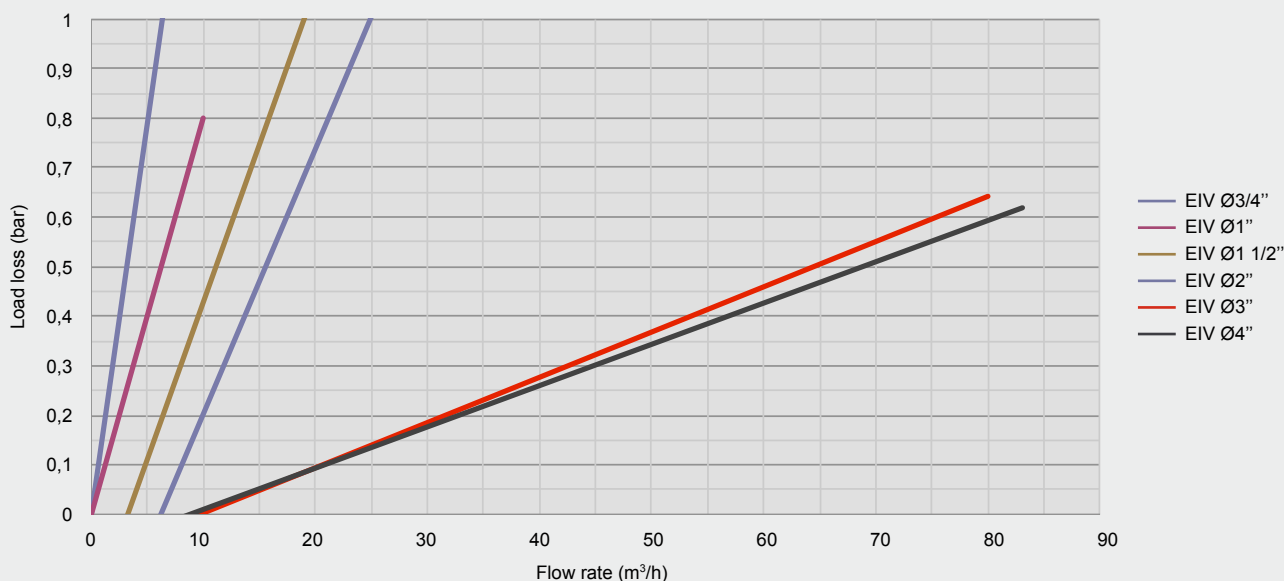

\*Testing for load loss was carried out with clean water.

# EIV

## Technical data

Bypasses	Pricelist ref.	Ø body (mm)	Flow rate (m³/h)	Filtration area (cm²)
Ø3/4"	IFEIV03 <b>H</b>	90,00	3 - 5	-
Ø1"	IFEIV10 <b>H</b>	90,00	5 - 12	-
Ø1 1/2"	IFEIV15 <b>H</b>	90,00	10 - 16	-
Ø2"	IFEIV20# <b>219</b>	219,00	15 - 25	-
Ø3"	IFEIV30# <b>219</b>	219,00	30 - 50	-
Ø3"	IFEIV30# <b>320</b>	320,00	40 - 60	-
Ø4"	IFEIV40# <b>320</b>	320,00	50 - 80	-
Ø5"	IFEIV50# <b>400</b>	400,00	80 - 120	-

## Dimensions

Ø (inches)	L (mm)	A (mm)	H (mm)	H1 (mm)	Tipo	Weight (kg)	
						H - W	F
3/4	285	55	582	660	A	----	----
1	285	55	782	860	A	----	----
1 1/2	285	55	782	860	A	----	----
2	500	-	1250	1050	B	----	----
3	620	-	1250	1050	B	----	----
3	620	-	1600	1300	B	----	----
4	620	-	1600	1300	B	----	----
5	620	-	1950	1600	B	----	----

Connection type: **H** female threaded; **F** flanged; **W** victaulic  
 Replace # with H (female threaded), F (flanged) or W (victaulic)

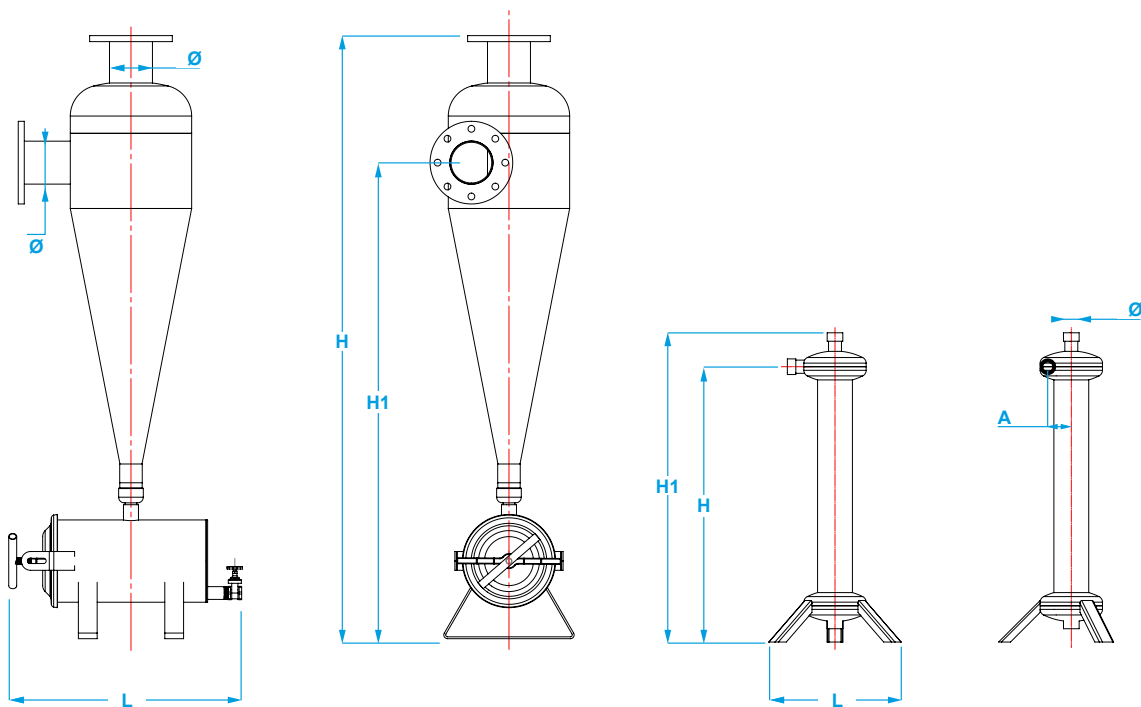

## Components

Number	Description
1	hydro-cyclone body
2	cover gasket
3	cover
4	t-handle
5	discharge valve
6	tank
7	reduction

